

THS/RB-800

HIGH PERFORMANCE METAL DETECTION SYSTEM WITH ROUND BELT FOR IN-LINE APPLICATIONS

CEIA introduces the new THS/RB-800 as the latest addition to the THS family.

This is an innovative and unique system designed for seamless and highly compatible integration into standard checkweigher systems and other in-line applications, so that maximum detection sensitivity can always be achieved. The THS/RB-800 offers a high performance cost effective solution where space and best performance are critical.

Main Features

- Compact conveyor system integrated with THS /SL21 series Metal Detectors
- Round belt design to eliminate metal contamination risk, thus achieving maximum sensitivity
- Hygienic and easy to inspect conveyor
- Conveyor skidplate and belt can be removed in seconds without tools for easy cleaning
- Digitally-adjustable belt speed, with the option of automatic synchronization with the following conveyor
- Fully compliant with HACCP criteria
- High immunity to environmental interference
- Very high sensitivity to all magnetic and non-magnetic metals, including stainless steel
- Multi-spectrum technology for the most accurate compensation of the product effect [MS21 series]
- Automatic learning & tracking of product effect
- Up to 500 product data memories, selectable by local programming or network software
- Up to 40 definable users with username and password



HOANG LONG TECHNOLOGY CO., LTD.

Hotline: 0907 686 889 - Email: info@congnghoanglong.com

www.maydokimloaiceia.vn

CEIA reserves the right to make changes, at any moment and without notice, to the models (including programming), their accessories and options, to the prices and conditions of sale

FT002K0014V4000hUK-71333

The new CEIA THS/RB-800 has been developed as a solution for seamless integration into any checkweigher system and other in-line applications. The main design considerations being a conveyor which allows the best sensitivity performance of the metal detector to be maintained throughout its lifetime.

At a length of 800 mm its footprint is small, and therefore it fits in the line taking up minimal space.

The simple electrical integration required allows the metal reject function to be carried out separately using the existing reject systems. Conveyor belt maintenance is minimal due to its unique design, which permits skidplate removal in seconds without the requirement for tools.

Technical Specifications

| | |
|--------------------------|----------------------------------|
| Conveyor belt length | 800 mm |
| Conveyor belt width | 200/300/400 mm |
| Conveyor belt height | 875 mm +/- 50 mm |
| Variable Belt speed | 20 - 60 m/min |
| Max weight on the belt | 5 Kg |
| Usable aperture height | 65/90/115/140/165 mm |
| Structure and components | AISI 304 |
| Surface Finishing | Polished |
| Protection degree | IP54 (IP65 available on request) |

Built-in encoder for following conveyor speed sensing

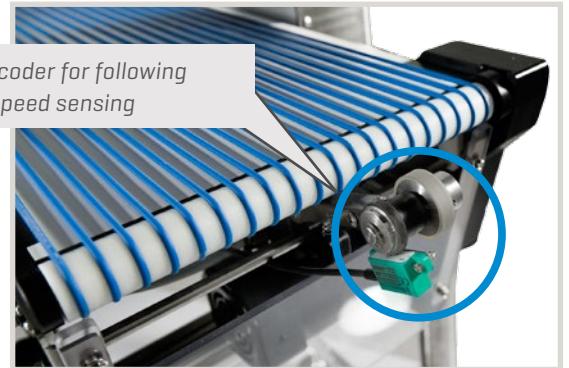

Round Polyurethane cord [FDA approved]



Mechanical Dimensions [mm]

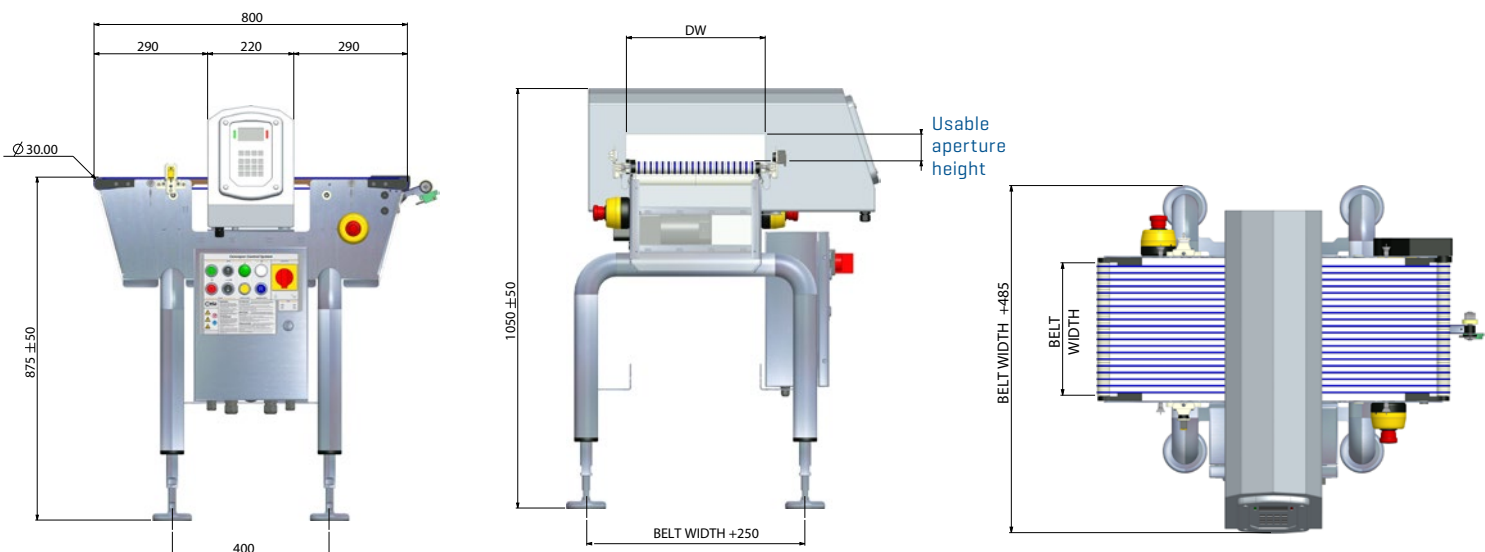

Easy to clean and maintain



| # | TOOL-FREE BELT REMOVAL |
|---|--|
| 1 | Extract the four locking pins |
| 2 | Lift the belt and the skid plate |
| 3 | Remove the belt and the skid plate from the conveyor |



Examples of installation

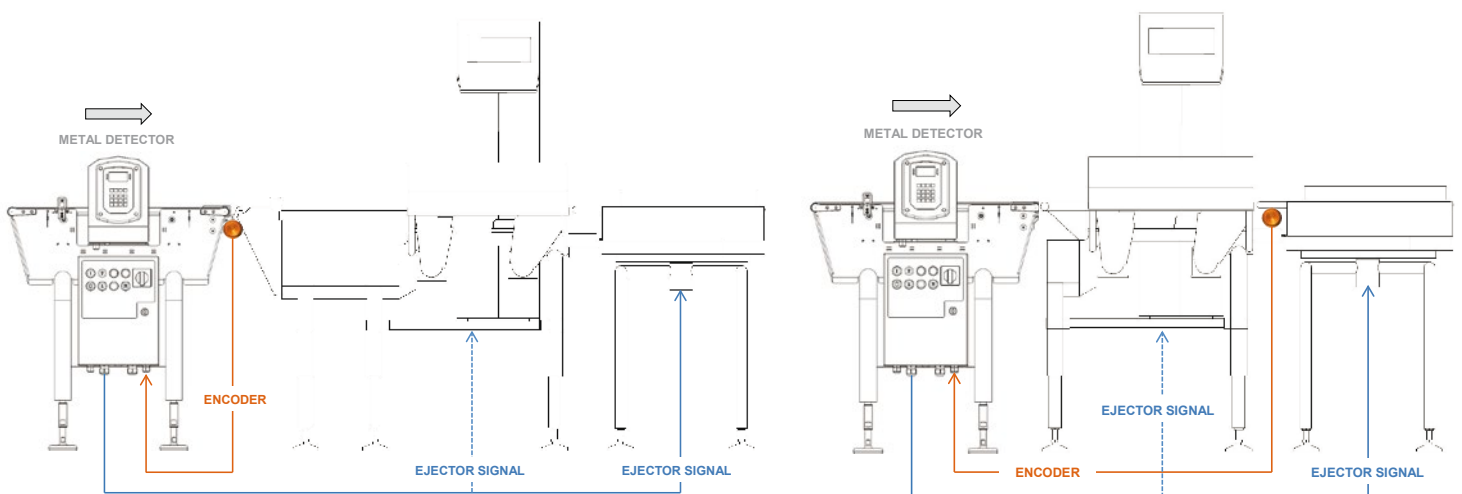

THS/RB Round Belt Configuration

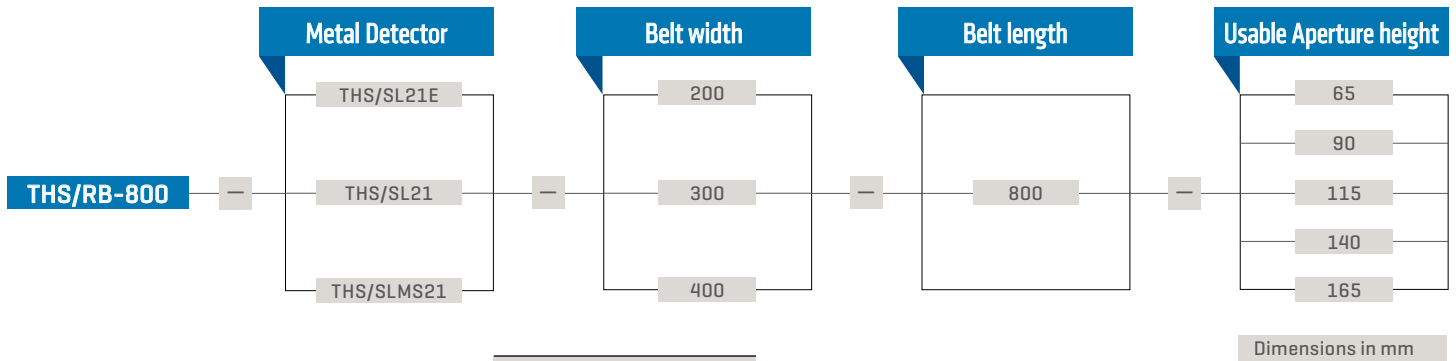

| | THS/RB-X-X-800-X |
|---|------------------|
| Synchronization photocell | ● |
| Variable speed | ● |
| Ejection output relay signal | ● |
| Built-in encoder for following conveyor speed sensing | ○ |

Standard ●
Option ○

Specifications

| | | |
|---------------------------------|--|--|
| GENERAL FEATURES | Conveyor belt integrated with Metal Detector | Easy to clean and maintain |
| | Full compliance with HACCP criteria | Multi-spectrum technology for most accurate compensation of the product effect |
| | Structure and components in stainless steel and food-compatible plastic parts (FDA, Usda compliant) | Very high sensitivity to all magnetic and non-magnetic metals, including stainless steel |
| | Control Panel listed according to UL 508A and CSA-C22.2 No. 14-05 available | Automatic learning and tracking of product effect |
| | Digitally-adjustable belt speed, with the option of automatic synchronization with the following conveyor | 500 product data memories, selectable by local programming or network software |
| | High immunity to environmental interference | Up to 40 definable users with username and password |
| DATA MANAGEMENT | Electronic Records and Signatures Management compliant with 21 CFR Part 11: Data Security, Data Integrity, Data Traceability | |
| EJECTION SYSTEMS | Output relay to drive one ejector placed in the following conveyor | |
| POWER SUPPLY | 100-120 Vac or 200-240 Vac, single phase - 50-60 Hz - 11.4A max | |
| CONTROL INPUTS | Downstream and upstream belt authorization | |
| ENVIRONMENTAL CONDITIONS | Operating temperature: 0°C to +50°C | |
| | Relative humidity: 5 to 90% (without condensation) | |
| DEGREE OF PROTECTION | Control System certified: Type 4X-12 (UL 50) available | |
| | Conveyor System: IP54 (IEC 529) - IP65 available on request | |
| SIGNALS | System completely monitored by self-diagnosis | |
| | Optical/acoustic signal for faults and alarms | |
| INTERFACE | RS-232 Serial interface | |
| | Bluetooth | |
| | Ethernet interface (on request) | |
| | Wi-Fi and USB (on request) | |
| MANAGEMENT SOFTWARE | THS Production software for statistical and operational management of networked THS systems | |
| | MD-SCOPE for local maintenance and programming operations | |



HOANG LONG TECHNOLOGY CO., LTD.

Hotline: 0907 686 889 - Email: info@congnghoanglong.com

www.maydokimloaiceia.vn

CEIA reserves the right to make changes, at any moment and without notice, to the models (including programming), their accessories and options, to the prices and conditions of sale

FT002K0014V4000hUK-71333